

SYGNALIZATOR ZACHOWANIA EDUPRINT

styczeń - czerwiec
2024

www.eduprint.pl

Produkt cyfrowy w formacie PDF jest własnością firmy Eduprint Aneta Wojtera i podlega ochronie z tytułu ustawy o prawie autorskim i prawach pokrewnych.
Za niedozwolone uważa się ich dalsze powielanie w formie elektronicznej, jak również dystrybuowanie, odsprzedaż oraz udostępnianie w Internecie.

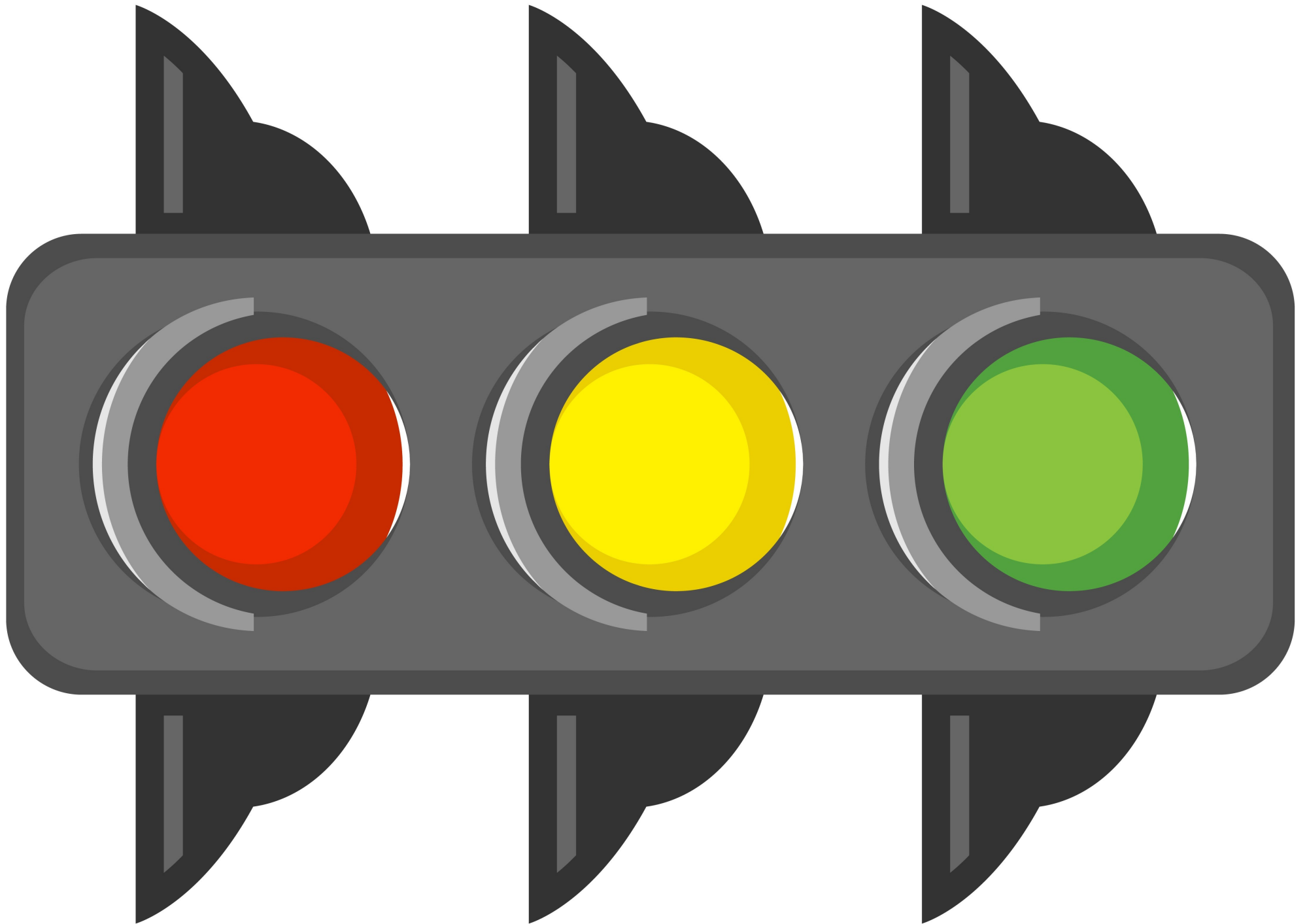

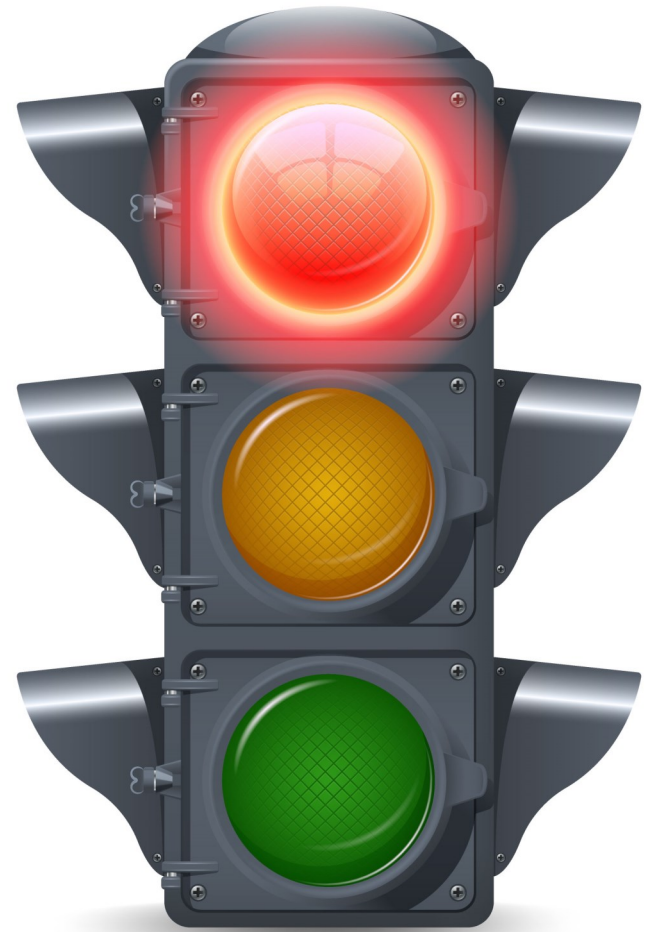
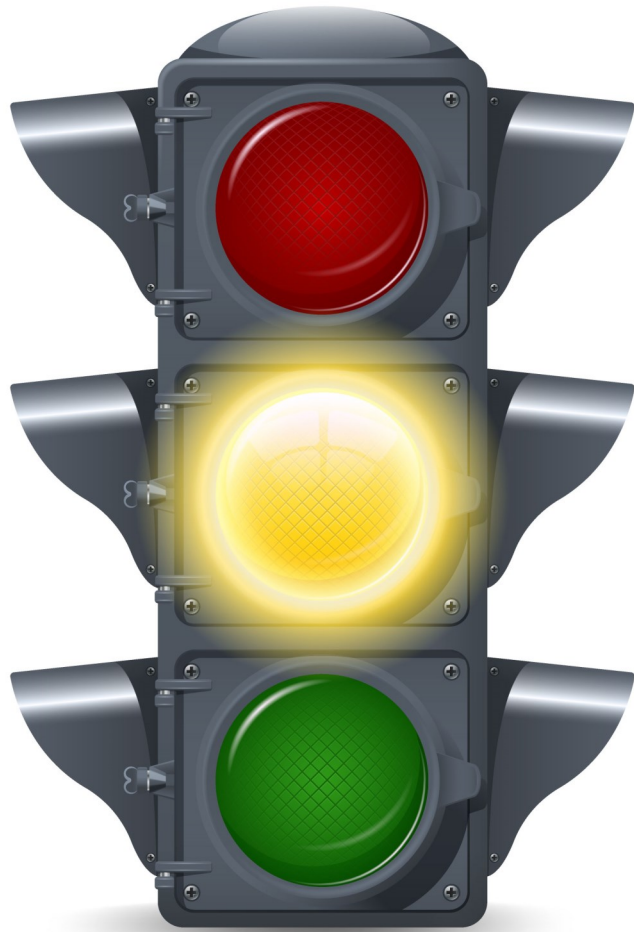
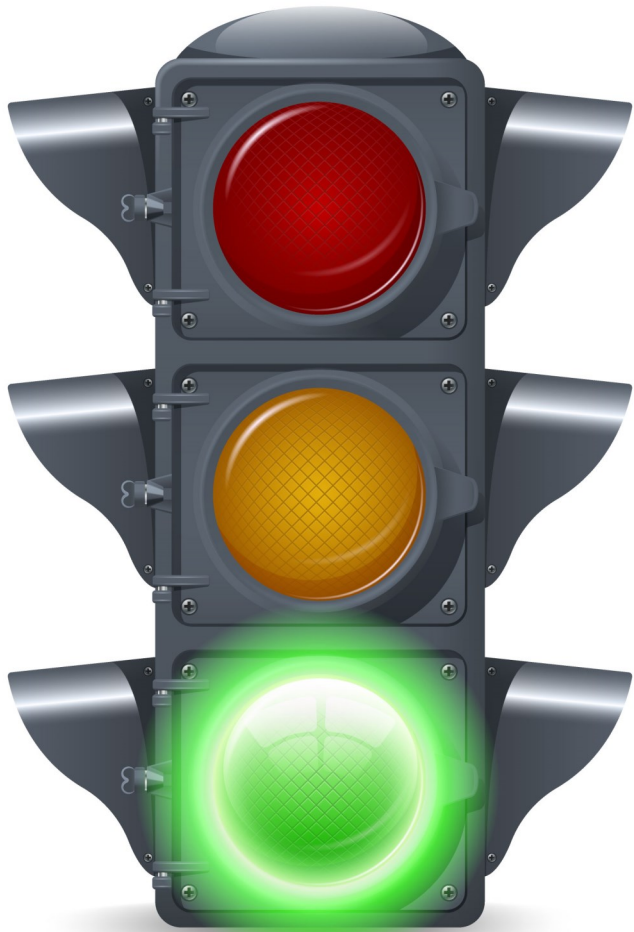

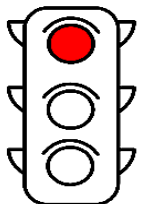

**BYŁEM UPOMINANY
I NIE POPRAWIŁEM SWOJEGO ZACHOWANIA.**

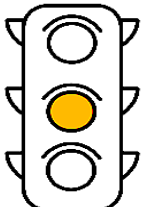

**BYŁEM UPOMINANY,
ALE POPRAWIŁEM SWOJE ZACHOWANIE.**

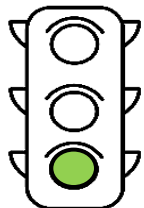

**MOJE ZACHOWANIE BYŁO WZOROWE.
MOGĘ BYĆ Z SIEBIE DUMNY.**

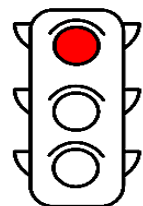

**BYŁEM UPOMINANY
I NIE POPRAWIŁEM SWOJEGO ZACHOWANIA.**

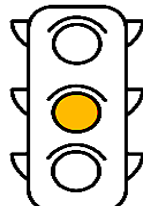

**BYŁEM UPOMINANY,
ALE POPRAWIŁEM SWOJE ZACHOWANIE.**

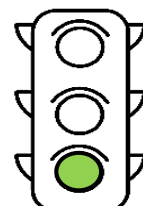

**MOJE ZACHOWANIE BYŁO WZOROWE.
MOGĘ BYĆ Z SIEBIE DUMNY.**

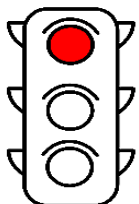

**BYŁEM UPOMINANY
I NIE POPRAWIŁEM SWOJEGO ZACHOWANIA.**

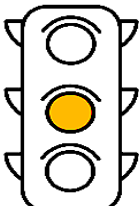

**BYŁEM UPOMINANY,
ALE POPRAWIŁEM SWOJE ZACHOWANIE.**

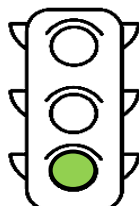

**MOJE ZACHOWANIE BYŁO WZOROWE.
MOGĘ BYĆ Z SIEBIE DUMNY.**

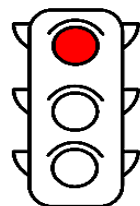

**BYŁEM UPOMINANY
I NIE POPRAWIŁEM SWOJEGO ZACHOWANIA.**

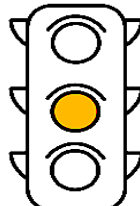

**BYŁEM UPOMINANY,
ALE POPRAWIŁEM SWOJE ZACHOWANIE.**

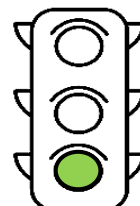

**MOJE ZACHOWANIE BYŁO WZOROWE.
MOGĘ BYĆ Z SIEBIE DUMNY.**

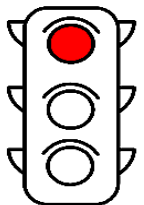

**BYŁAM UPOMINANA
I NIE POPRAWIŁAM SWOJEGO ZACHOWANIA.**

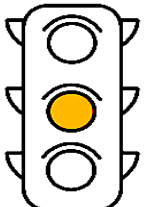

**BYŁAM UPOMINANA,
ALE POPRAWIŁAM SWOJE ZACHOWANIE.**

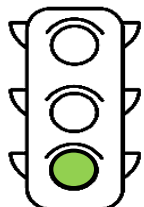

**MOJE ZACHOWANIE BYŁO WZOROWE.
MOGĘ BYĆ Z SIEBIE DUMNA.**

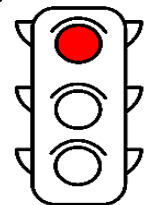

**BYŁAM UPOMINANA
I NIE POPRAWIŁAM SWOJEGO ZACHOWANIA.**

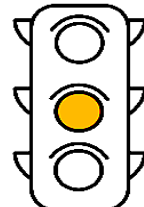

**BYŁAM UPOMINANA,
ALE POPRAWIŁAM SWOJE ZACHOWANIE.**

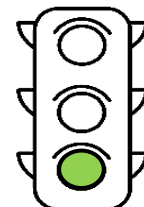

**MOJE ZACHOWANIE BYŁO WZOROWE.
MOGĘ BYĆ Z SIEBIE DUMNA.**

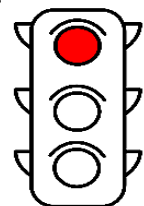

**BYŁAM UPOMINANA
I NIE POPRAWIŁAM SWOJEGO ZACHOWANIA.**

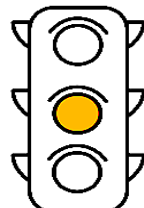

**BYŁAM UPOMINANA,
ALE POPRAWIŁAM SWOJE ZACHOWANIE.**

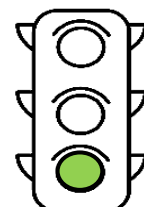

**MOJE ZACHOWANIE BYŁO WZOROWE.
MOGĘ BYĆ Z SIEBIE DUMNA.**

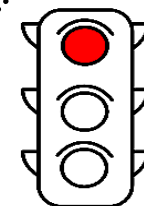

**BYŁAM UPOMINANA
I NIE POPRAWIŁAM SWOJEGO ZACHOWANIA.**

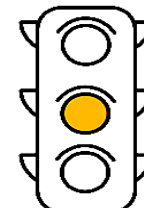

**BYŁAM UPOMINANA,
ALE POPRAWIŁAM SWOJE ZACHOWANIE.**

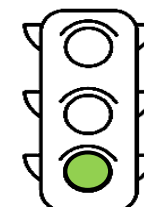

**MOJE ZACHOWANIE BYŁO WZOROWE.
MOGĘ BYĆ Z SIEBIE DUMNA.**

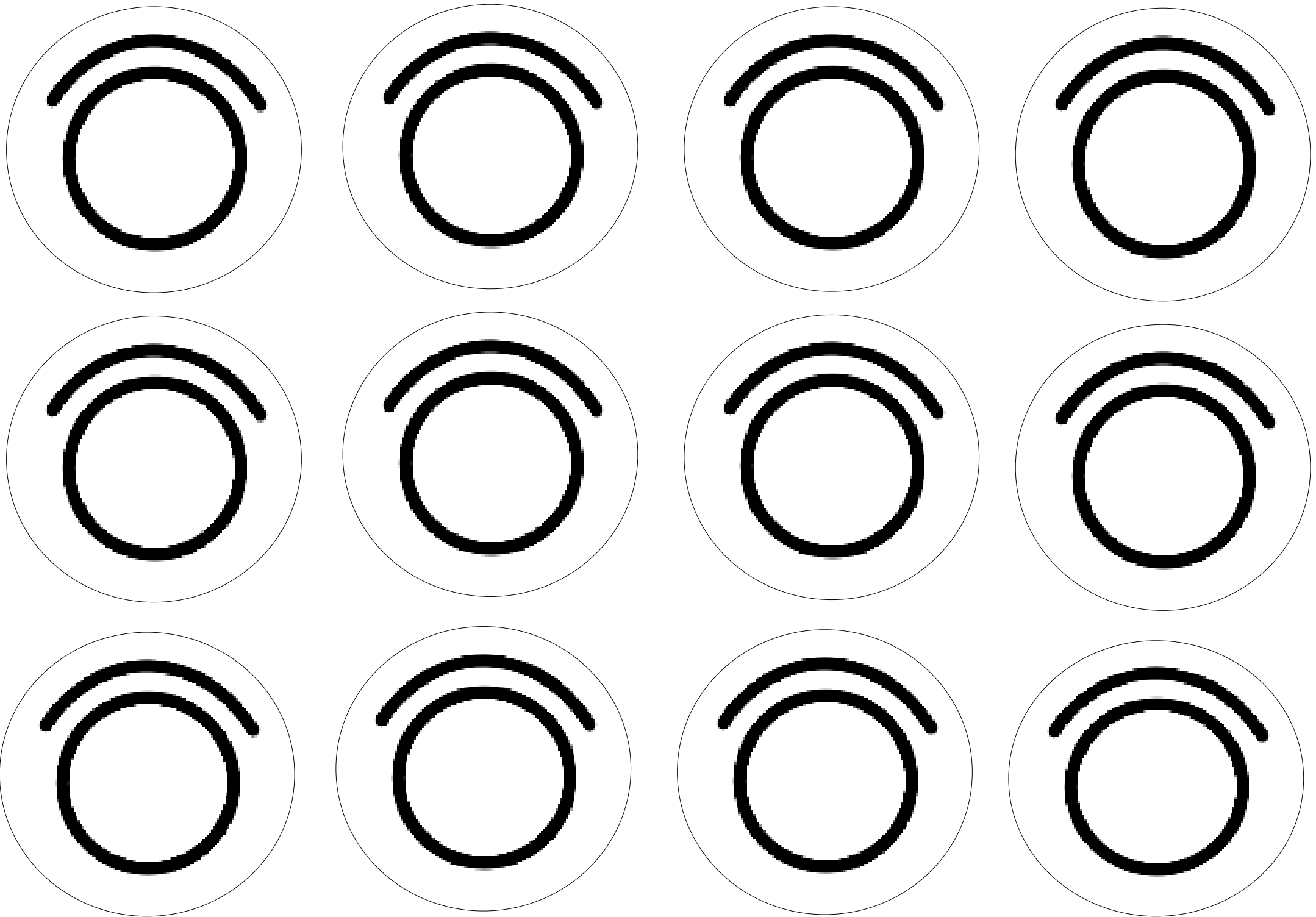

Żetony do rozdania – wydrukuj na zielonym, żółtym i czerwonym papierze, zalaminuj. Rozdaj na początku zajęć zielony żeton.

Mój styczniowy sygnalizator zachowania



2.01	3.01	4.01	5.01	8.01	9.01		
10.01	11.01	12.01	15.01	16.01	17.01	18.01	19.01
22.01	23.01	24.01	25.01	26.01	29.01	30.01	31.01

Mój styczniowy sygnalizator zachowania



2.01	3.01	4.01	5.01	8.01	9.01		
10.01	11.01	12.01	15.01	16.01	17.01	18.01	19.01
22.01	23.01	24.01	25.01	26.01	29.01	30.01	31.01

Mój styczniowy sygnalizator zachowania



2.01	3.01	4.01	5.01	8.01	9.01		
10.01	11.01	12.01	15.01	16.01	17.01	18.01	19.01
22.01	23.01	24.01	25.01	26.01	29.01	30.01	31.01

Mój styczniowy sygnalizator zachowania



2.01	3.01	4.01	5.01	8.01	9.01		
10.01	11.01	12.01	15.01	16.01	17.01	18.01	19.01
22.01	23.01	24.01	25.01	26.01	29.01	30.01	31.01

Mój styczniowy
sygnalizator
zachowania



3.01	4.01	5.01	8.01	9.01			
10.01	11.01	12.01	15.01	16.01	17.01	18.01	19.01
22.01	23.01	24.01	25.01	26.01	29.01	30.01	31.01

Mój styczniowy
sygnalizator
zachowania



3.01	4.01	5.01	8.01	9.01			
10.01	11.01	12.01	15.01	16.01	17.01	18.01	19.01
22.01	23.01	24.01	25.01	26.01	29.01	30.01	31.01

Mój styczniowy
sygnalizator
zachowania



3.01	4.01	5.01	8.01	9.01			
10.01	11.01	12.01	15.01	16.01	17.01	18.01	19.01
22.01	23.01	24.01	25.01	26.01	29.01	30.01	31.01

Mój styczniowy
sygnalizator
zachowania



3.01	4.01	5.01	8.01	9.01			
10.01	11.01	12.01	15.01	16.01	17.01	18.01	19.01
22.01	23.01	24.01	25.01	26.01	29.01	30.01	31.01

Mój styczniowy
sygnalizator
zachowania



2.01 3.01 4.01 5.01 8.01 9.01

10.01 11.01 12.01 15.01 16.01 17.01 18.01 19.01

12 empty signal light icons arranged in two rows of six.

Mój styczniowy
sygnalizator
zachowania



2.01 3.01 4.01 5.01 8.01 9.01

10.01 11.01 12.01 15.01 16.01 17.01 18.01 19.01

12 empty signal light icons arranged in two rows of six.

Mój styczniowy
sygnalizator
zachowania



2.01 3.01 4.01 5.01 8.01 9.01

10.01 11.01 12.01 15.01 16.01 17.01 18.01 19.01

12 empty signal light icons arranged in two rows of six.

Mój styczniowy
sygnalizator
zachowania



2.01 3.01 4.01 5.01 8.01 9.01

10.01 11.01 12.01 15.01 16.01 17.01 18.01 19.01

12 empty signal light icons arranged in two rows of six.

Mój styczniowy
sygnalizator
zachowania



2.01 3.01 4.01 5.01 8.01 9.01

10.01 11.01 12.01 15.01 16.01 17.01 18.01 19.01

12 empty signal light icons arranged in two rows of six.

Mój styczniowy
sygnalizator
zachowania



2.01 3.01 4.01 5.01 8.01 9.01

10.01 11.01 12.01 15.01 16.01 17.01 18.01 19.01

12 empty signal light icons arranged in two rows of six.



Mój lutowy sygnalizator zachowania

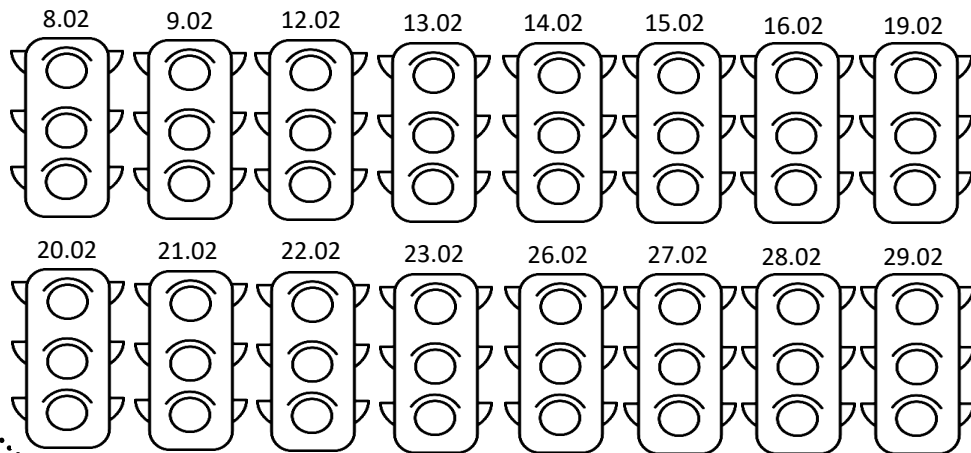
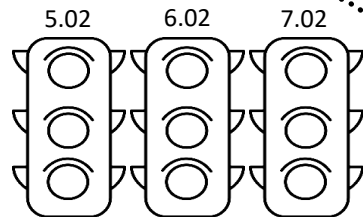

Mój lutowy sygnalizator zachowania

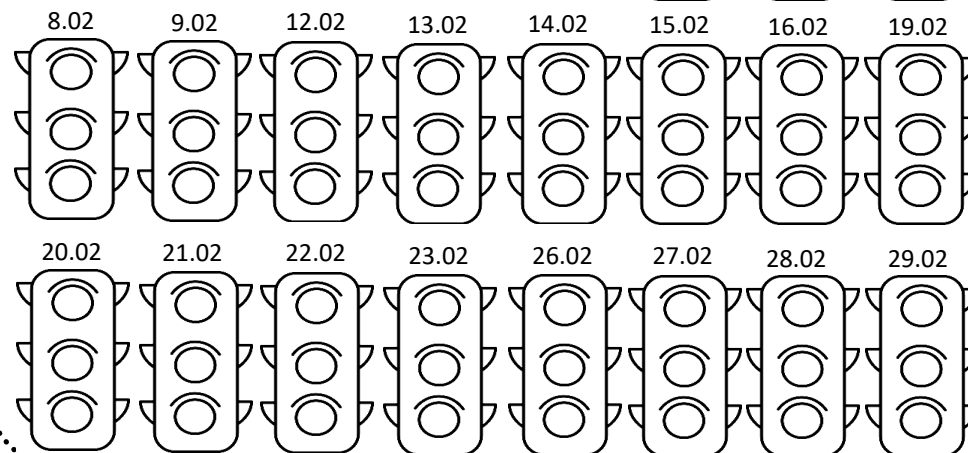
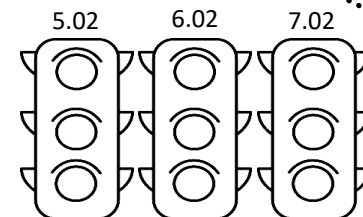

Mój lutowy sygnalizator zachowania

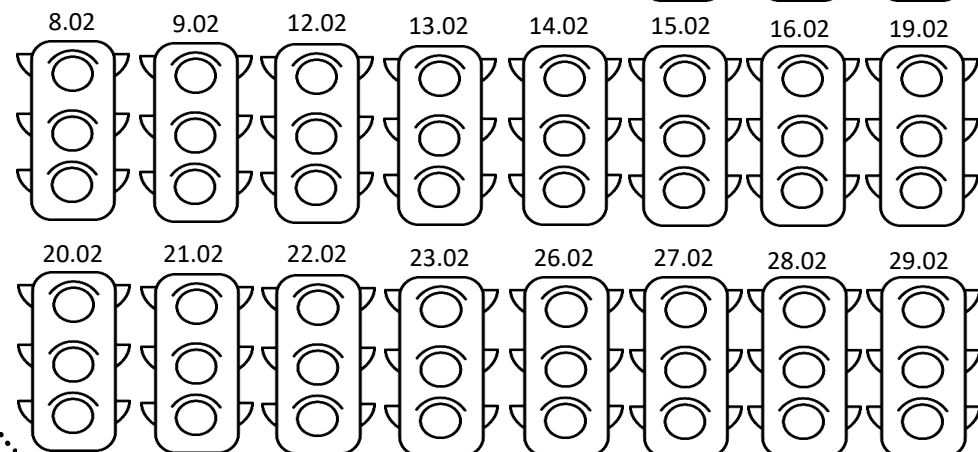
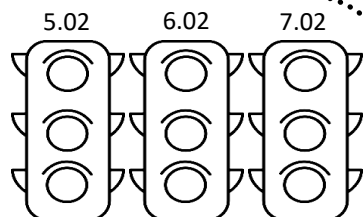

Mój lutowy sygnalizator zachowania

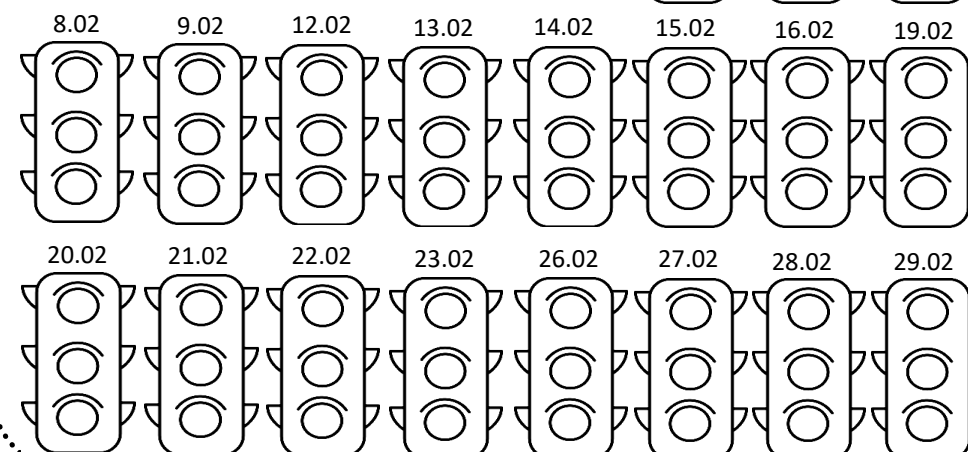
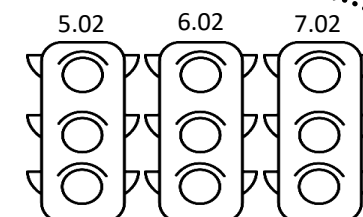

Mój lutowy

sygnalizator zachowania

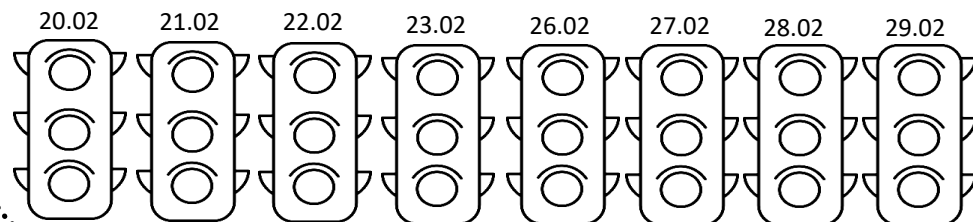
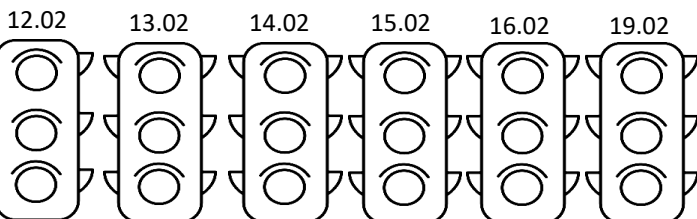

Mój lutowy

sygnalizator zachowania

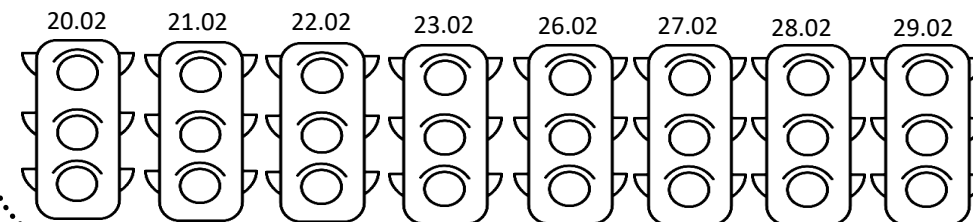
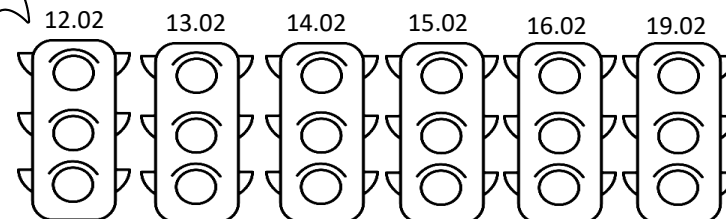
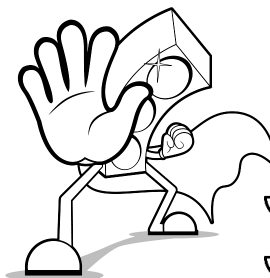

Mój lutowy

sygnalizator zachowania

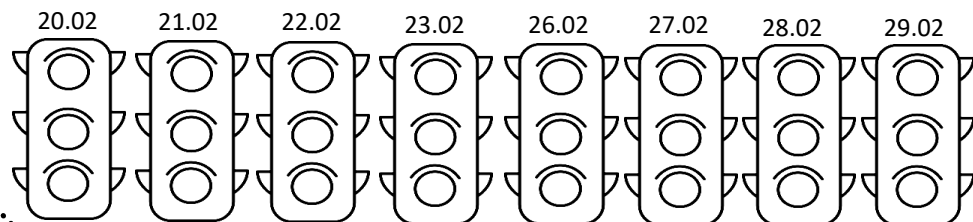
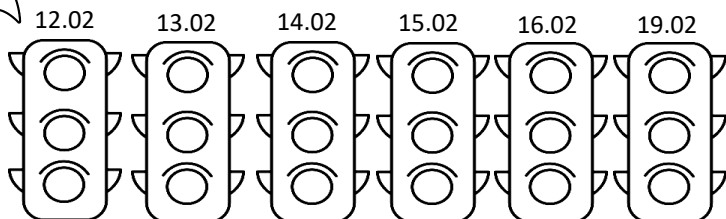

Mój lutowy

sygnalizator zachowania

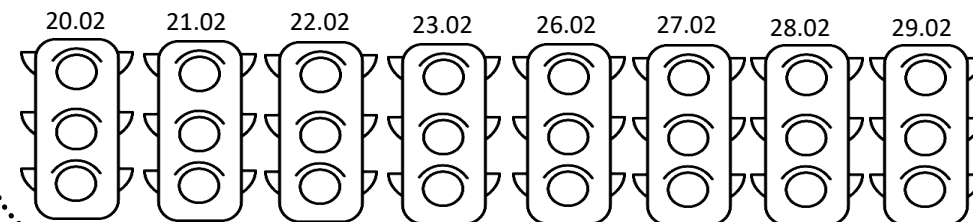
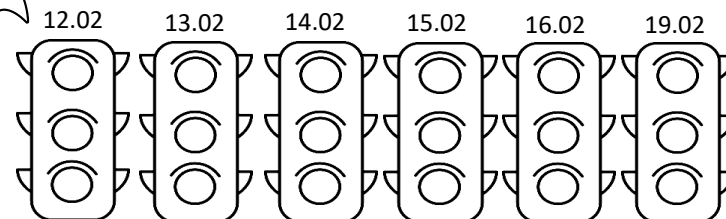
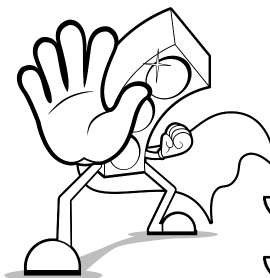

1.02 2.02 5.02 6.02 7.02 8.02 9.02

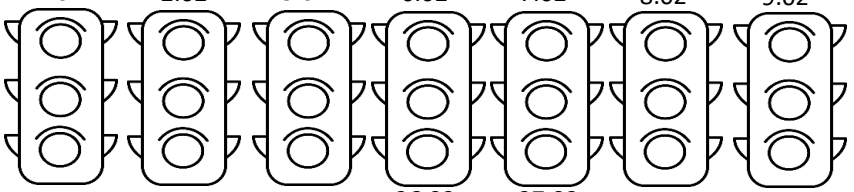

26.02 27.02 28.02 29.02

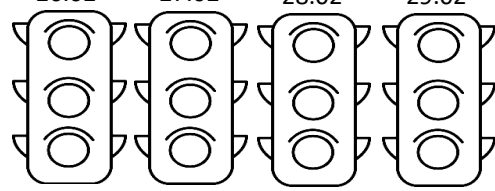

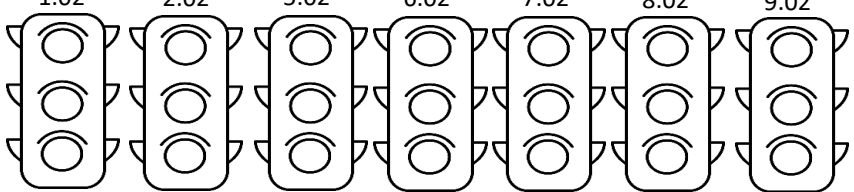

 **Mój lutowy**
sygnalizator
zachowania

1.02 2.02 5.02 6.02 7.02 8.02 9.02

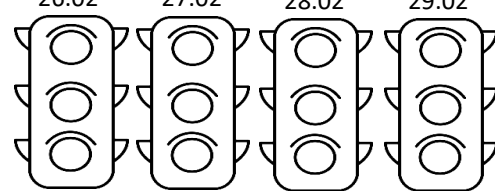

26.02 27.02 28.02 29.02



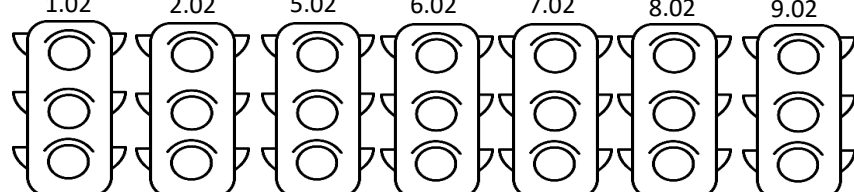

 **Mój lutowy**
sygnalizator
zachowania

1.02 2.02 5.02 6.02 7.02 8.02 9.02

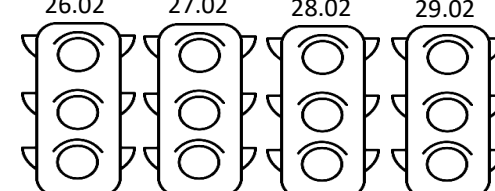

26.02 27.02 28.02 29.02



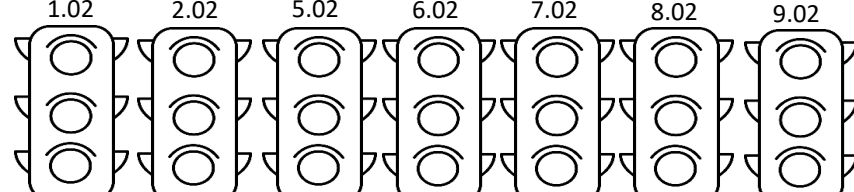

 **Mój lutowy**
sygnalizator
zachowania

1.02 2.02 5.02 6.02 7.02 8.02 9.02

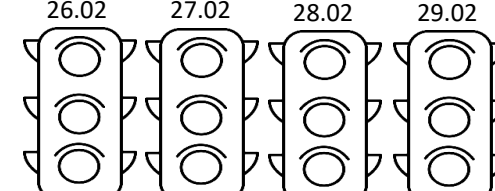

26.02 27.02 28.02 29.02



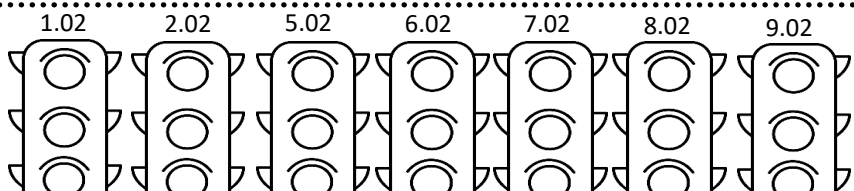

 **Mój lutowy**
sygnalizator
zachowania

1.02 2.02 5.02 6.02 7.02 8.02 9.02

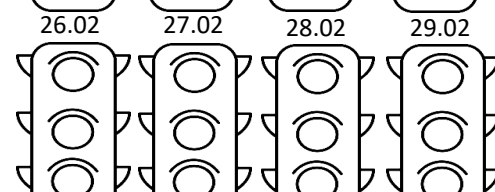

26.02 27.02 28.02 29.02



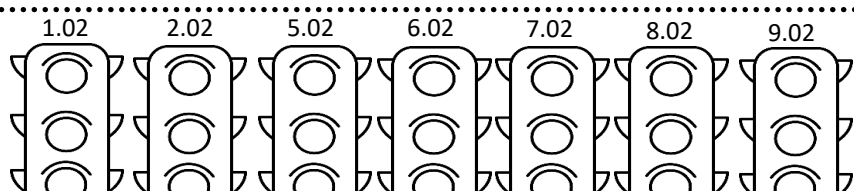

 **Mój lutowy**
sygnalizator
zachowania

1.02 2.02 5.02 6.02 7.02 8.02 9.02

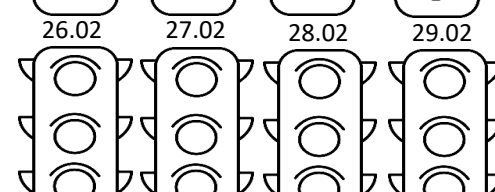

26.02 27.02 28.02 29.02



 **Mój lutowy**
sygnalizator
zachowania



Mój marcowy sygnalizator zachowania

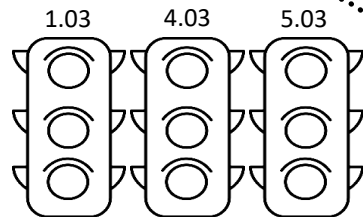

1.03 4.03 5.03

6.03 7.03 8.03 11.03 12.03 13.03 14.02 15.03

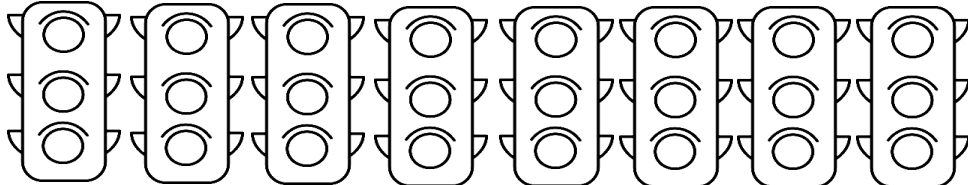

18.03 19.03 20.03 21.03 22.03 25.03 26.03 27.03

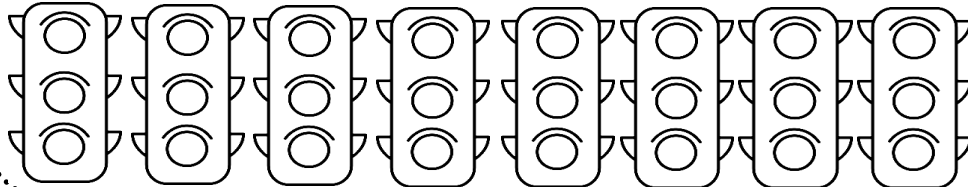

Mój marcowy sygnalizator zachowania

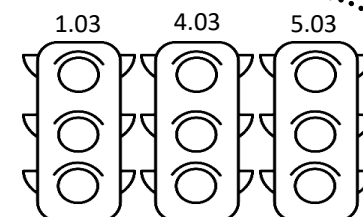

1.03 4.03 5.03

6.03 7.03 8.03 11.03 12.03 13.03 14.02 15.03

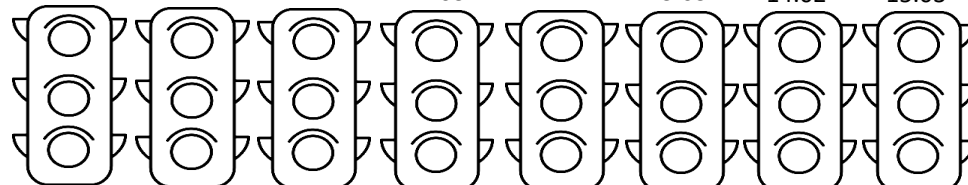

18.03 19.03 20.03 21.03 22.03 25.03 26.03 27.03

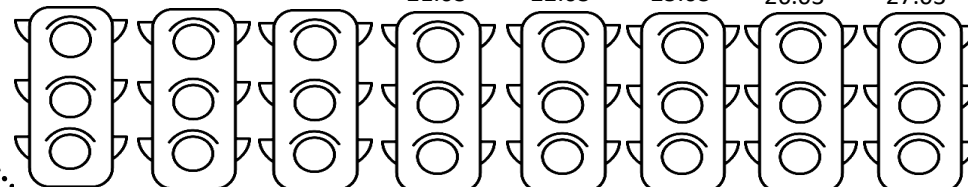

Mój marcowy sygnalizator zachowania

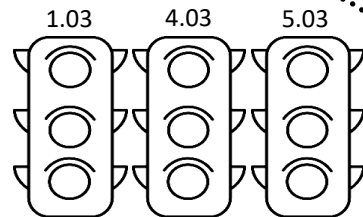

1.03 4.03 5.03

6.03 7.03 8.03 11.03 12.03 13.03 14.02 15.03

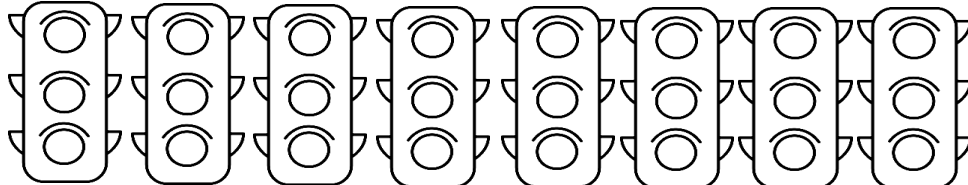

18.03 19.03 20.03 21.03 22.03 25.03 26.03 27.03

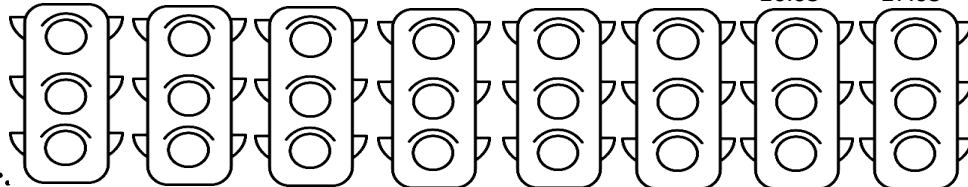

Mój marcowy sygnalizator zachowania

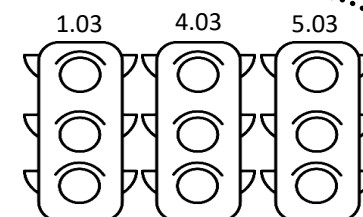

1.03 4.03 5.03

6.03 7.03 8.03 11.03 12.03 13.03 14.02 15.03

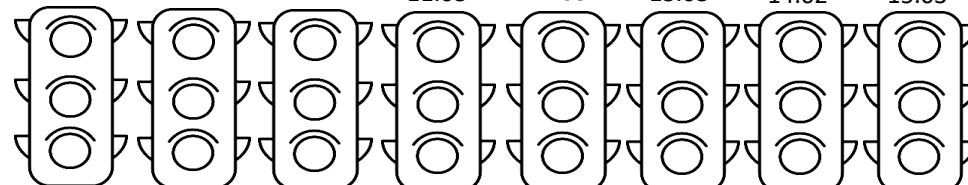

18.03 19.03 20.03 21.03 22.03 25.03 26.03 27.03

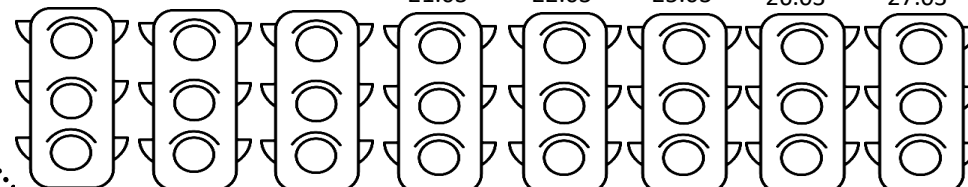

Mój kwietniowy
sygnalizator
zachowania



3.04 4.04 5.04 8.04

9.04 10.04 11.04 12.04 15.04 16.04 17.04 18.04

19.04 22.04 23.04 24.04 25.04 26.04 29.04 30.04

This section contains a grid of 28 empty traffic light icons for the month of April. The dates are arranged in three rows: the first row has 4 icons (3.04, 4.04, 5.04, 8.04), the second row has 8 icons (9.04, 10.04, 11.04, 12.04, 15.04, 16.04, 17.04, 18.04), and the third row has 8 icons (19.04, 22.04, 23.04, 24.04, 25.04, 26.04, 29.04, 30.04). Each icon is a vertical rectangle with three circles inside, representing a traffic light.

Mój kwietniowy
sygnalizator
zachowania



3.04 4.04 5.04 8.04

9.04 10.04 11.04 12.04 15.04 16.04 17.04 18.04

19.04 22.04 23.04 24.04 25.04 26.04 29.04 30.04

This section is identical to the top-left section, containing a grid of 28 empty traffic light icons for the month of April with the same date labels.

Mój kwietniowy
sygnalizator
zachowania



3.04 4.04 5.04 8.04

9.04 10.04 11.04 12.04 15.04 16.04 17.04 18.04

19.04 22.04 23.04 24.04 25.04 26.04 29.04 30.04

This section is identical to the top-left section, containing a grid of 28 empty traffic light icons for the month of April with the same date labels.

Mój kwietniowy
sygnalizator
zachowania



3.04 4.04 5.04 8.04

9.04 10.04 11.04 12.04 15.04 16.04 17.04 18.04

19.04 22.04 23.04 24.04 25.04 26.04 29.04 30.04

This section is identical to the top-left section, containing a grid of 28 empty traffic light icons for the month of April with the same date labels.

